

DC Single-Acting High Performance Solenoids

1

Product group

G T C A

Function

- Increasing magnetic force vs. stroke characteristic
- Push and pull type

Construction

- Robust closed cylindrical design
- Fastening with flange or through three tapped holes
- 7 sizes \varnothing (mm) 40, 50, 60, 70, 80, 90, 100
- Armature guided in maintenance free bearings. High service life
- Insulation materials of the excitation winding correspond to thermal class F
- Electrical connection via free flexible lead ends or connector plug type Z KB according to DIN EN 175301-803
- Protection class according to DIN VDE/DIN EN 60529, when properly installed
 - Free flexible lead ends IP 00
 - Receptacles according to DIN 46247 IP 00
 - Plug connection via connector plug Z KB IP 54

Application examples

- Tooling machines, packing machines, textile machines
- Measuring and control technology

Options and accessories

- Delivery with and without flange
- Horizontal characteristic on request
- Double acting execution (type GTUW, sep. part list)
- Energy or force optimisation by operation with holding current reduction type Z KD H 211 (sep. part list)
- Plug connectors
 - without rectifier type Z KB X 211 B01
 - with rectifier type Z KB G 211 A02
- Fork joint (type Z GA)

Standards

- Design and testing according to DIN VDE 0580
- Production according to ISO 9001



Fig. 1: Type G T C A 090 X43 A02

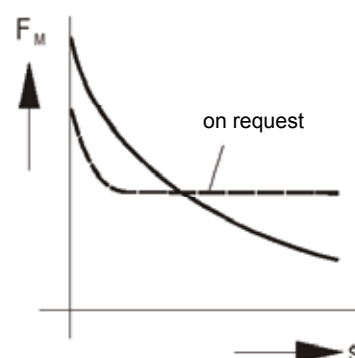

Fig. 2: Force vs. stroke characteristic

Technical data

G T C A		40						50					
Operating mode		S1 100%	S3 40%	S3 25%	S3 15%	S3 5%	mit HSA ²⁾	S1 100%	S3 40%	S3 25%	S3 15%	S3 5% ¹⁾	mit HSA ²⁾
Stroke s (mm)		Magnetic force F_M (N)						Magnetic force F_M (N)					
0		34,8	53,7	67,9	80	131	57	92	136	166	195	258	123
2		11,8	18,7	24,9	30	56	59	21	37	54	72	116	98
3		10,7	17,0	22,2	27	50	53	19	32	46	63	104	88
4		9,8	15,9	20,7	25	47	50	17	29	41	57	97	82
5		8,6	14,5	19,2	23	44	47	16	27	38	52	92	77
6		7,6	13,6	18,3	22	42	44	15	26	36	49	87	73
8		6,0	11,9	16,9	21	39	41	14	24	33	45	80	67
10								13	24	33	44	76	63
Rated work A_N (Ncm)		4,8	9,5	13,5	16,8	31,2	32,4	13	24	33	44	76	63
Rated power P_{20} (W)		12,9	28	41	52	156	see p. 7	17	34	60	99	270	see p. 7
Operating frequency S_h (1/h)		26000	11000	7500	4000	1500	---	19500	8500	6000	3500	1500	---
Actuation time t_1 (ms)		75	70	67	66	57	57	107	93	87	81	70	71
Fall time t_2 (ms)		62	59	57	56	53	46	76	68	65	62	48	51
Inductance $L^{(3)}$ (mH)		ca. 250 $\xrightarrow{\text{decreasing}}$						ca. 300 $\xrightarrow{\text{decreasing}}$					
• Armature in stroke start position s_{max}		ca. 250						ca. 300					
• Armature in stroke end position s_0		ca. 200						ca. 200					
Armature weight m_A (kg)		0,08						0,13					
Solenoid weight m_M (kg)		0,36						0,69					
G T C A		60						70					
Operating mode		S1 100%	S3 40%	S3 25%	S3 15%	S3 5% ¹⁾	mit HSA ²⁾	S1 100%	S3 40%	S3 25%	S3 15%	S3 5% ¹⁾	mit HSA ²⁾
Stroke s (mm)		Magnetic force F_M (N)						Magnetic force F_M (N)					
0		118	179	207	249	356	164	187	243	282	326	449	227
2		38	68	83	109	186	118	78	113	135	157	250	172
3		35	62	76	99	171	106	71	104	124	144	228	158
4		34	57	71	92	162	98	67	98	118	138	217	150
5		32	54	67	88	156	92	63	94	114	133	211	145
6		31	51	63	83	151	87	59	90	110	129	207	141
8		28	48	58	76	143	79	52	83	103	122	201	132
10		25	45	55	71	137	74	46	76	96	115	197	124
12		22	42	52	68	131	72	40	71	90	109	192	117
15								31	61	81	99	182	108
Rated work A_N (Ncm)		26	50	63	82	157	86	46	92	121	148	272	162
Rated power P_{20} (W)		26	54	77	107	377	see p. 7	33	70	118	142	447	see p. 7
Operating frequency S_h (1/h)		16000	7000	4500	3000	1000	---	13500	6000	4000	2500	950	---
Actuation time t_1 (ms)		132	119	110	100	83	93	156	135	125	118	106	114
Fall time t_2 (ms)		89	78	71	65	70	67	110	95	92	87	75	73
Inductance $L^{(3)}$ (mH)		ca. 250 $\xrightarrow{\text{decreasing}}$						ca. 250 $\xrightarrow{\text{decreasing}}$					
• Armature in stroke start position s_{max}		ca. 250						ca. 250					
• Armature in stroke end position s_0		ca. 200						ca. 200					
Armature weight m_A (kg)		0,22						0,35					
Solenoid weight m_M (kg)		1,16						1,86					

G T C A		80						90					
Operating mode		S1 100%	S3 40%	S3 25%	S3 15%	S3 5% ¹⁾	mit HSA ²⁾	S1 100%	S3 40%	S3 25%	S3 15% ¹⁾	S3 5% ¹⁾	mit HSA ²⁾
Stroke s (mm)		Magnetic force F _M (N)						Magnetic force F _M (N)					
0		211	304	370	442	574	285	220	326	383	453	692	260
5		60	94	117	147	254	140	85	130	156	199	330	158
10		50	82	104	132	223	127	77	126	152	192	301	153
15		39	72	93	121	212	114	65	121	149	190	296	145
20		29	61	82	109	201	102	48	104	134	177	286	129
25								34	80	111	157	263	106
Rated work A _N (Ncm)		58	122	163	217	401	205	86	200	277	393	658	265
Rated power P ₂₀ (W)		31	71	119	185	588	see p. 7	51	131	202	318	823	see p. 7
Operating frequency S _h (1/h)		10000	4500	3000	2000	900	---	9000	4000	2500	1500	700	---
Actuation time t ₁ (ms)		197	175	155	135	109	137	215	180	170	163	154	180
Fall time t ₂ (ms)		137	114	110	97	81	100	180	142	130	119	100	133
Inductance L ³⁾ (mH)													
* Armature in stroke start position s _{max}		ca. 350	→ decreasing →					ca. 250	→ decreasing →				
* Armature in stroke end position s ₀		ca. 200						ca. 150					
Armature weight m _A (kg)		0,48						0,82					
Solenoid weight m _M (kg)		2,62						4,02					
G T C A		100											
Operating mode		S1 100%	S3 40%	S3 25%	S3 15% ¹⁾	S3 5% ¹⁾	mit HSA ²⁾						
Stroke s (mm)		Magnetic force F _M (N)											
0		307	437	537	741	969	327						
5		113	150	196	269	450	156						
10		114	155	198	262	413	163						
15		107	150	195	259	401	161						
20		96	141	184	251	391	151						
25		85	131	174	241	388	144						
30		69	118	163	225	371	132						
Rated work A _N (Ncm)		207	354	488	676	1112	397						
Rated power P ₂₀ (W)		69	155	197	403	853	see p. 7						
Operating frequency S _h (1/h)		7500	3000	2000	1500	500	---						
Actuation time t ₁ (ms)		303	262	231	193	176	236						
Fall time t ₂ (ms)		174	156	148	141	117	146						
Inductance L ³⁾ (mH)													
* Armature in stroke start position s _{max}		ca. 150	→ decreasing →										
* Armature in stroke end position s ₀		ca. 100											
Armature weight m _A (kg)		1,22											
Solenoid weight m _M (kg)		5,81											

¹⁾ For versions with connector plug, **not** available in rated voltage 24 V due to max. current load of 10 A

²⁾ Forces for the operation of the solenoid with overexcitation using special winding holding current reduction (HAS, cycle time 300s, 100% duty cycle) in conjunction with connector ZKDH211A01 for comparison with the force values when operating the devices without holding current reduction. Actuation forces are specified for actuation current, holding forces (stroke = 0) for a reduced holding current. For further information see pages 6/7.

³⁾ Inductance measured with LCR measuring bridge 3255B (by Wayne Kerr). Converted for rated voltage 24V

Note on the tables

The magnetic force values stated in the tables refer to series G TC A ... X 43 A01 with 90 % rated voltage and the normal operation condition. This was determined according to VDE 0580 § 35 on a poor heat conducting base.

For other rated voltages deviations of the magnetic force may occur. The magnetic force values may deviate by approx. ± 10 % due to natural dispersion.

Current load connector plug

For versions with connector plug (G TC A ...X43 A01/A02) it has to be observed that the max. admissible rated current is 10 A.

The rated current is calculated from the rated voltage and the rated power P₂₀ indicated in the tables on page 2 and 3:

Example :

Rated voltage: 12V
 Rated power GTCA 100 5%ED: 855W
 Calculation of the rated current:

$$I_{20} = \frac{P_{20}}{U_N} = \frac{855W}{12V} = 71,25 A$$

In this case the current admissible for the mating connector is exceeded; it must be switched to a version with free lead ends.

The normal operating condition is based on:

- a) Rated voltage = 24 V
- b) Operating mode S1 (100 %)
- c) Reference temperature 35° C

Rated voltage

Rated voltage = 24 V. For versions with connector, the exciter coil can be adjusted to a rated voltage of max. = 250 V on request.

The devices with free lead ends G TC A ... X20 A01/A02 (fig. 5/6) comply with protection class III. Electrical equipment of protection class III may be only connected to low voltage systems (PELV, SELV)(IEC 60364-4-41). For DC the design limits of the equipment is a rated voltage not higher than 120 V (EN 61140:2002). On request we are pleased to check to what extent the delivery of higher rated voltages is possible as special solutions by agreement.

Note on the application of series G TC A via rectifier

The connection to the AC network is possible when using a rectifier. Under consideration of the admissible current (max. 2A, see derating curve in part list Z KB X...) the plug connector Z KB G 211 A02 may be used. With higher currents it is required to install a separate rectifier outside the solenoid.

It is to be observed that the AC networks are largely free of voltage peaks. If bigger inductances and capacities are switched very close to the devices, it must be ensured that these voltage peaks are rendered ineffective by suitable switching means (throttle resp. bond-pass filters).

Information and remarks concerning European directives can be taken from the correspondent information sheet which is available under *Produktinfo.Magnet-Schultz.com*.

Note on the RoHS Directive

The devices presented in this document do not fall into the scope of RoHS Directive and to our knowledge they do not become part of products which fall into this scope. In case of surfaces zinc coating with yellow chromating and zinc iron with black chromating separate agreements are necessary for applications within the scope of RoHS.

Please make sure that the described devices are suitable for your application. Supplementary information concerning its proper installation can be taken also from the –Technical Explanation, the effective DIN VDE0580 as well as the relevant specifications.

This part list is a document for technically qualified personnel.

The present publication is for informational purposes only and shall not be construed as mandatory illustration of the products unless otherwise confirmed expressively.

Dimensional drawings

G T C A							
Size	40	50	60	70	80	90	100
Dimensions in mm							
a1	50	60	70	80	90	100	110
a2	7	11,5	12	14	14	16	20
d1	40	50	60	70	80	90	100
d2	22	25	32	38	42	52	58
d3	24	27	34	40	44	54	60
d4	M5	M5	M6	M8	M10	M12	M12
d5	4,8	5,8	5,8	7	9,5	9,5	11,5
d6	M3	M4	M5	M5	M6	M6	M8
d7	20	23	28	32	35	42	48
d8	24	28	34	38	45	52	56
d9	25	28	35,5	40	44	54	58
e	38	46	54	62	72	80	88
f	3	3	2,5	5	5	5	5
h1	51,5	61,5	71,5 ^{±1,5}	81,5 ^{±1,5}	91,5 ^{±1,5}	101,5 ^{±1,5}	111,5 ^{±1,5}
k	30	34	45	52	62	68	76
l1	45	55	65	74	79	93	110
l2	50	64,5	74,5	85	90	105	125
l4	60,5	80	92	104,5	115	135	159
l5	29	30	33	39	50	60	61
l6	37	40	45	54	70	85	91
l7	32	30,5	35,5	43	59	73	76
l9	15	16	16,4	23,5	32	37,5	37,5
l10	15	15	18	20	30	40	40
l11	111	125	143	167	199	238	262
l12	7	10,5	12,5	15,5	21	26	31
l13	4,5	10	10	12	13	15	19
l14	4	4	4	5	5	5	6
l15	150	150	200	200	200	200	250
l16	0,5	0,5	0,5	1	2	3	4
l17	121,5	140,5	160,5	186,5	224	268	296
s	8	10	12	15	20	25	30
sw	4,5	4,5	3	7	9	10	10
¹⁾ t1	4	5	6	6	8	8	11
¹⁾ t2	9	9	8	10	13	15	13
Fork end Z GA K*	50	50	60	80	100	120	120
Screw tightening moment (Nm)	M3	M4	M5	M5	M6	M6	M8
	1,6	2,3	4,4	4,4	7,7	7,7	18,5

* see part list Z GA

¹⁾ Please do not exceed the thread depth t_1 and t_2 as this may cause a damage of the coil.

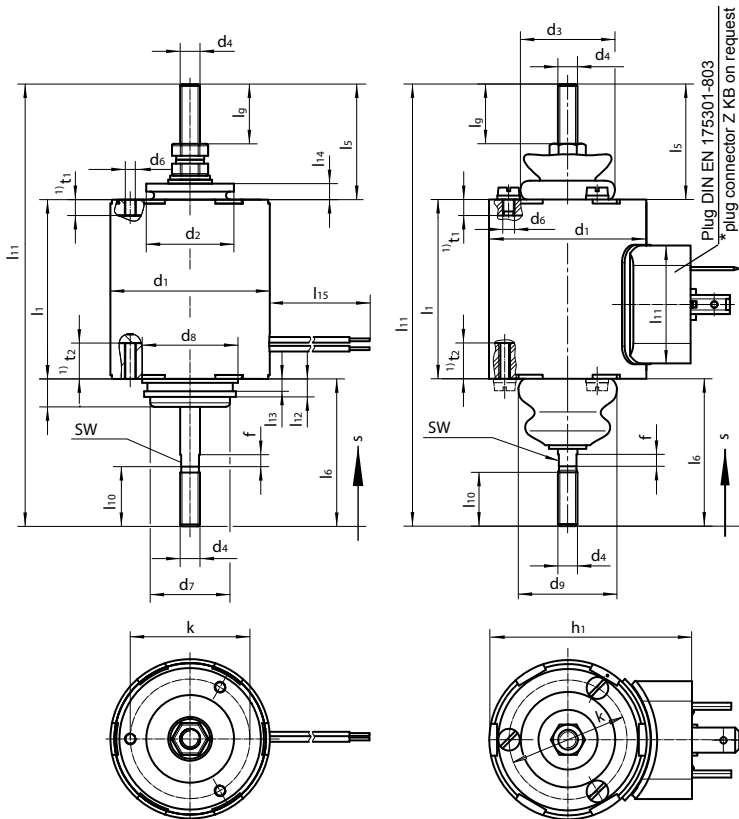

Fig. 5: G T C A 040 X20 A01 to G T C A 100 X20 A01

Fig. 7: G T C A 040 X43 A01 to G T C A 100 X43 A01
* see part list Z KB

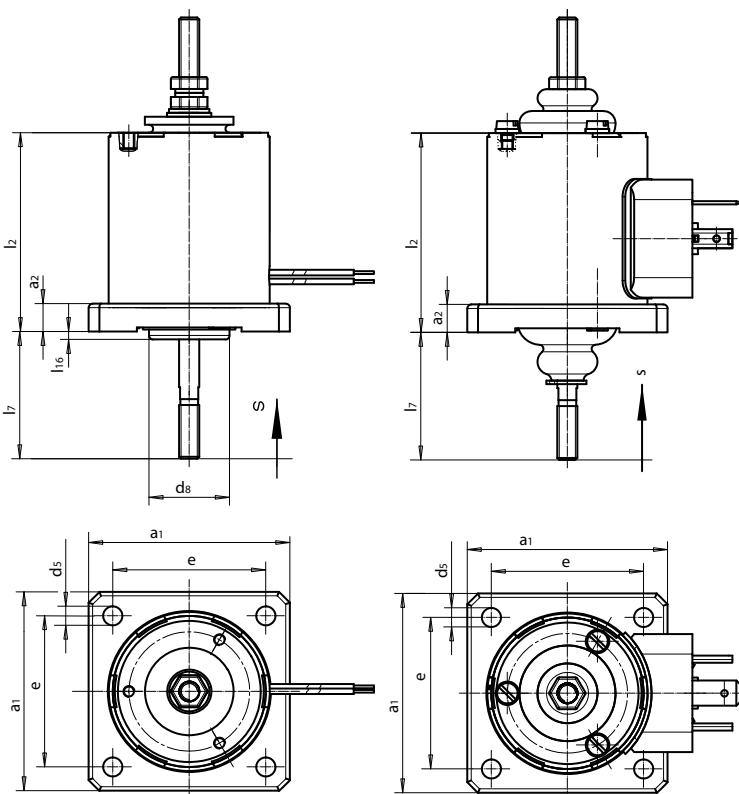

Fig. 6: G T C A 040 X20 A02 to G T C A 100 X20 A02
(missing dimensions see fig. 5)

Fig. 8: G T C A 040 X43 A02 to G T C A 100 X43 A02
(missing dimensions see fig. 7)

Operation of devices type GTCA with holding current reduction Z KD H 211

The operation of solenoids with control electronics Z KD H offers the possibility to optimise the device with regard to actuation force or energy efficiency.

Optimizing of the actuation force (overexcitation)

The solenoid has to be equipped with an adapted winding ex factory. This winding features a reduced resistance and thus achieves a higher performance with rated voltage. The thermal overload by increased performance of the solenoid is avoided by the fact that after the actuation pulse duration of 300 ms the holding current reduction Z KD H 211 lowers the current on a reduced holding current to be set according to the admissible holding performance.

In order to illustrate the efficiency of the combination of solenoid and electronic control system, the achievable actuation forces and/or holding force are illustrated by the example of a special winding which is designed for a cycle time of 300 s (5 min), 100% duty cycle (= no pause between 2 switching cycles) and the actuation pulse duration of 300 ms which is permanently set in the electronic system (HSA, 100%).

The indicated actuation forces result from the actuation current I_A of max. 10 A in consideration of the admissible voltage tolerances.

By reducing the duty cycle (pause between 2 switching cycles) further increases of the actuation performance and thus the actuation forces are possible with other winding designs. With the same winding it is possible to increase the holding current by reducing the duty cycle and thus to achieve higher holding forces.

For additional technical data see table on page 7

Optimizing of the energy efficiency

To increase the energy efficiency of the solenoid the holding current reduction Z KD H 211 is used with the standard winding 100 %, without any further adaption. The holding force is adjusted via the holding current at the electronics.

For further information please refer to part list Z KD H 211 and the related operating manual.

We will be pleased to assist you in finding a solution for your electromagnetic task. Please contact the technical office responsible for you.

Technical data for the operation with holding current reduction
Z KD H 211, exemplary for special winding HSA (cycle time
300s, duty cycle 100 %)

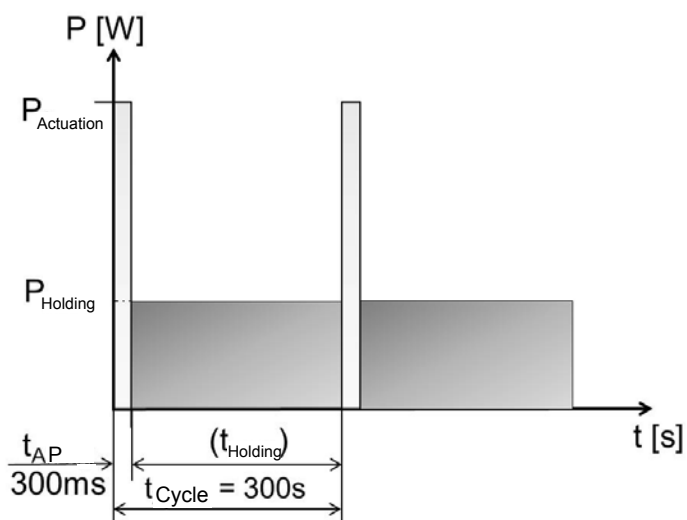

Fig. 9: Illustration of the operating cycle

G T C A		40	50	60	70	80	90	100
Rated work A_N	(Ncm)	32,4	63	86	162	205	265	397,2
Rated power P_{20}	(W)	9,7	14	18	25	27	29	31,6
Actuation force $P_{Actuation\ 20}$	(W)	178	192	148	197	185	178	165
Max. holding force $P_{Holding\ 20}$	(W)	14,8	21,6	28,6	39,2	41,3	55,1	48,7
Average power $P_{Average\ 20}$	(W)	15,0	21,8	28,7	39,4	41,4	55,2	48,8
Actuation time t_1	(ms)	57	71	93	114	137	180	237
Fall time t_2	(ms)	46	51	67	73	100	133	146
Reference temperature	(°C)	35						
Operating mode		100%ED						
Actuation pulse duration t_{AP}	(s)	0,3						
Holding time $t_{Holding}$	(s)	299,7						
Cycle time t_{Cycle}	(s)	300						

Key for type designation

Exam- ple	GTCA	090	X43 A01	Designation	Voltage admissible duty cycle for rated voltage 24V					
					100%	40%	25%	15%	5%	HSA 100%
Type	GTCA									
Construction size = main diameter (mm)		040			X	X	X	X	X	X
		050			X	X	X	X		X
		060			X	X	X	X		X
		070			X	X	X	X		X
		080			X	X	X	X		X
		090			X	X	X			X
		100			X	X	X			X
Indicator for version & protection class			X20 A01	Free lead ends, without flange	24V DC (max. 120V) without protective conductor connection, protection class III					
			X20 A02	Free lead ends, pull side						
			X43 A01	Connector plug, without flange, bellow	24V DC, 205V DC (max. 250V) protection class I					
			X43 A02	Connector plug, flange pull side, bellow						

Order example

Type G TC A 090 X20 A01
Voltage == 24 V DC
Operating mode S1 (100 %)

Specials designs

Please do not hesitate to ask us for application-oriented problem solutions. In order to find rapidly a reliable solution we need complete details about your application conditions. The details should be specified as precisely as possible in accordance with the relevant  -Technical Explanations.

If necessary, please request the support of our corresponding technical office.