

DC Holding magnet

Optionally with or without armature

Optionally with polished or zinc-coated pole face

9

Product group

G MH G ZZ

Function

- High holding force
- Increasing force vs. stroke characteristic
- Gimbal mounted armature

Construction

- Fastening via thread bores on the rear side
- Insulation materials of the excitation winding correspond to thermal class B
- Electrical connection via free flexible lead ends or via bipolar clamp
- Protection class according to DIN VDE/DIN EN 60529 when it is properly installed
 - Free flexible lead ends: IP 00
 - bipolar clamp: IP 20
- Pole face optionally polished or zinc-coated

Application examples

- Mechanical engineering and fixture construction, conveyor technology, door holding systems
- Interlocking of all sorts
- Use as control solenoid for short strokes

Options

- Protection class IP 65 on request

Standards

- Design and testing according to DIN VDE 0580
- Production according to ISO 9001



Fig. 1: Holding magnet with armature
Type G MH X 065 X20 A01 and
Type G ZZ E 065 X00 A01

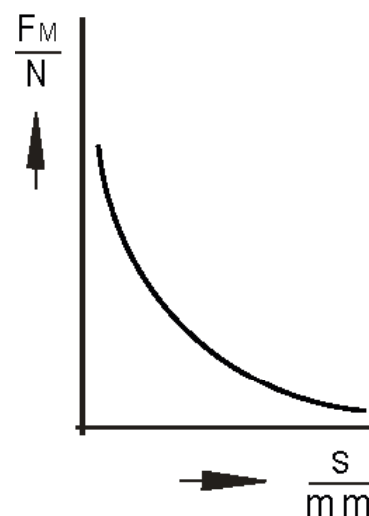

Fig. 2: force vs. stroke characteristic

Technical data

G MH X		020	025	030	040	050	065	080	100
Operating mode		S1 100%	S1 100%	S1 100%	S1 100%	S1 100%	S1 100%	S1 100%	S1 100%
Rated power P ₂₀	(W)	1,9	3,2	4	5,6	6,2	9,8	12,4	17
Solenoid weight m _M	(kg)	0,025	0,07	0,1	0,22	0,38	0,75	1,3	2,2
Armature weight m _A	(kg)	0,007	0,012	0,029	0,05	0,1	0,21	0,4	0,74
Armature thickness	(mm)	2,5	3	5	5	6	8	10	12
Armature diameter Ø	(mm)	20	25	30	40	50	65	80	100
Stroke s	(mm)	Magnetic force F _M (N)							
... A01 (polished pole face)	0	88	150	280	520	800	1480	2280	3700
... A11 (zinc-coated pole face)	0	80	135	250	470	720	1330	2050	3330
	0,1	10	36,3	70	275	569	1128	1942	3140
	0,16	6	18,2	38	157	373	883	1600	2747
	0,25	2,1	9,8	20	80	216	618	1256	2354
	0,4	0,5	3,5	10	30	93	294	657	1520
	0,6	—	1,8	5	14	41	132	314	804
	1,0	—	0,9	2	6,2	18	61	128	324
	1,6	—	—	—	2,6	7	18	45	137
	2,5	—	—	—	1,3	2,2	10	18	58
	4	—	—	—	0,5	0,8	3,2	9,8	26
	6	—	—	—	—	0,4	2,6	4,9	11
Magnetic force F _M ¹⁾ at stroke of 0mm with armature G ZZ E for ... A01 for ... A11		70 63	130 115	230 210	420 380	700 630	1200 1080	1850 1660	3000 2700

1) The armatures are corrosion protected through nickel-coating. The nickel-coat which is not magnetically conducting causes an air gap, so the above mentioned magnetic forces can be measured. The adhesive force is approximately 5% of the magnetic force at 0 mm stroke. The external return forces must be above this adhesive force with a sufficient safety margin.

Notes on the tables

The force values indicated in the tables refer to 90 % of the rated voltage, (U_N = 24 V, for other voltages deviations of magnetic force may occur) and in the normal operating temperature.

Due to natural dispersion the magnetic force values may deviate by approx. ± 10 % from the table values.

The normal operating temperature is based on:

- Rated voltage = 24 V
- Operating mode S1 100%
- Reference temperature 35° C
- Mounting on heat-insulating base

Rated voltage

Rated voltage is 24 V. An adaptation of the exciter coil to a rated voltage less than 120 V is possible on request.

The devices correspond to protection class III. Electrical equipment of protection class III may be only connected to low voltage systems (PELV, SELV)(IEC 60364-4-41). The design limit of the equipment is a rated voltage not higher than 120 V (EN 61140:2002) with DC. On request we are pleased to check to what extent the delivery of higher rated voltages is possible as special solutions by agreement.

In the interest of a low surface temperature, the excessive temperature of the devices is $\Delta_{v,32} = 60$ K. The magnetic force values are measured using a specimen made of 9 S Mn 28 with plane ground surface and a surface roughness of 15 µm max. On request an increase of the magnetic force is possible by a special adjustment of the winding. If the specimen thickness is small, the magnetic force is reduced. The use of materials with other permeability or bad surface quality may cause higher deviations of the rated force.

The pole face of types ...A01 is polished. This causes higher holding forces at increased susceptibility to corrosion. In case that due to the ambient conditions corrosion on the pole face must be expected, we recommend using type ...A11 with zinc-coated pole face but slightly reduced holding forces.

Dimension tables

Solenoid without armature

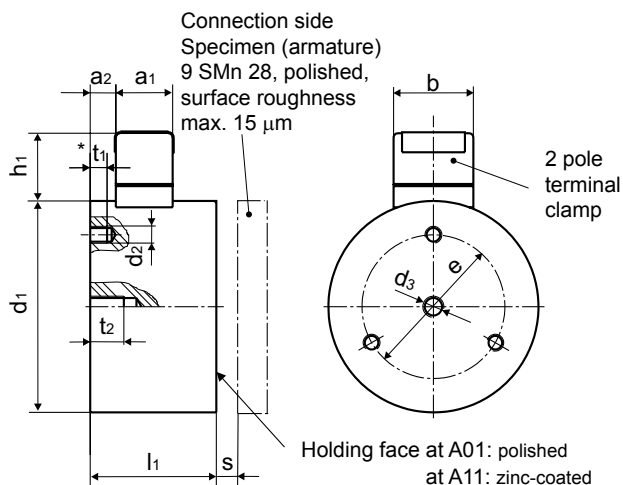

Fig. 3: Type G MH X 025 X 20 A01 / A11
to G MH X 100 X 20 A01 / A11

G MH X								
Größe	020	025	030	040	050	065	080	100
Maß	Maße in mm							
a ₁	—	13,5	13,5	13,5	13,5	13,5	13,5	13,5
a ₂	—	4,5	5,6	6	6	7	8,5	11
b	—	19	19	19	19	19	19	19
d ₁	20	25	30	40	50	65	80	100
d ₂	—	M3	M3	M4	M4	M5	M6	M6
d ₃	M4	M4	M5	M5	M5	M8	M8	M10
e	—	15	18	26	34	40	50	75
h ₁	—	16	16	16	16	16	16	16
l ₁	15	20	24	27	30	35	38	43
l ₂	150	150	150	150	150	150	150	150
l ₃	10,5	11,4	15	17,4	20,4	24,4	25,8	28,3
*t ₁	—	3	4	4	4	5	7	7
t ₂	4	6	5	8	8	12	12	15

* We cannot exceed the thread depth t, this could damage the coil.

Size 020 is not available with terminal clamp.

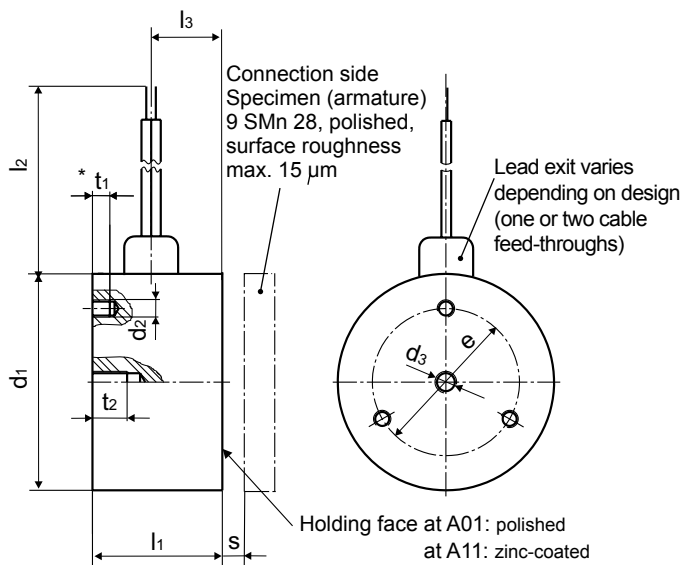

Fig. 4: Type G MH X 020 X 00 A01 / A11
to G MH X 100 X 00 A01 / A11

Information and remarks concerning European directives can be taken from the correspondent information sheet which is available under Produktinfo.Magnet-Schultz.com.

Note on the RoHS Directive

According to our current state of knowledge the devices pictured in this document do not contain any substances in concentration values or applications for which putting into circulation with products manufactured from them is prohibited in accordance to RoHS.

Please make sure that the described devices are suitable for your application. Supplementary information concerning its proper installation can be taken also from the -Technical Explanation, the effective DIN VDE0580 as well as the relevant specifications.

This part list is a document for technically qualified personnel.

The present publication is for informational purposes only and shall not be construed as mandatory illustration of the products unless otherwise confirmed expressly.

Armature for solenoids

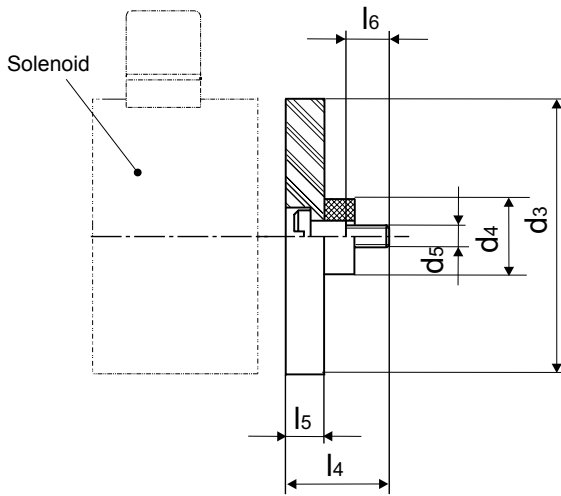

Fig. 5: Type G ZZ E 020 X 00 A01
to G ZZ E 100 X 00 A01
(size 030: ... D01)

G ZZ E								
Size	020	025	030	040	050	065	080	100
Dim.	Dimensions in mm							
d ₃	20	25	30	40	50	65	80	100
d ₄	7	8	10,5	10,5	10,5	13,5	16	21,5
d ₅	M2,5	M3	M4	M4	M4	M5	M6	M8
l ₄	8,5	9,5	14	14	15	19	23	26
l ₅	2,5	3	5	5	6	8	10	12
l ₆	3,5	4,5	6	6	6	7	9	11

Design with pin-socket on request

Type code

G MH X 050 X 20 A01	
Device group	G
Series	MH
Modifications	X
Size in the series	050
Execution in the series	X
Protection code	20
Design number	A01: polished pole face A11: zinc-coated pole face

Order example

(Holding magnet without armature)

Type G MH X 050 X20 A01
Voltage \equiv 24 V DC
Operating mode S1 (100 %)

(Holding magnet with armature)

Type G MH X 050 X20 A01
G ZZ E 050 X00 A01
Voltage \equiv 24 V DC
Operating mode S1 (100 %)

Permanent holding magnets see part lists
G MP and **G MP ... B01**.

Specials designs

Please do not hesitate to ask us for application-oriented problem solutions. In order to find rapidly a reliable solution we need complete details about your application conditions. The details should be specified as precisely as possible in accordance with the relevant -Technical Explanations.

If necessary, please request the support of our corresponding technical office.